



Standard Guide for Digital Communication Protocols for Computerized Systems¹

This standard is issued under the fixed designation F1757; the number immediately following the designation indicates the year of original adoption or, in the case of revision, the year of last revision. A number in parentheses indicates the year of last reapproval. A superscript epsilon (ϵ) indicates an editorial change since the last revision or reapproval.

1. Scope

1.1 The principal content of this guide provides a road map to implement a communication network applicable to ship and marine computer systems by:

1.1.1 Examining the relationship of digital communication protocols as a network technological infrastructure,

1.1.2 Outlining the basic building blocks of network topologies and transmission techniques associated with the implementation of transmission media in a network environment; and,

1.1.3 Identifying operating system and environments.

1.2 Using the Open System Interconnection (OSI) model, which provides a layered approach to network functionality and evaluation, common network communications protocols are identified and characterized in this guide according to lower and upper layer protocols corresponding to their degree and type of functionality.

1.3 Although it is desirable that network users, designers, and administrators recognize and understand every possible networking protocol, it is not possible to know the intimate details of every protocol specification. Accordingly, this guide is not intended to address fully every hardware and software protocol ever developed for commercial use, which spans a period of about 25 years. Instead, the user of this guide will be introduced to a brief overview of the majority of past and present protocols which may comprise a ship or marine internetwork, to include Local Area Networks (LANs), Wide Area Networks (WANs), and related hardware and software that provide such network interoperability and data transfer.

1.4 While this guide provides an understanding of the wide range of communication protocols, the user is recommended to consult the reference material for acquiring a more comprehensive understanding of individual communication protocols. However, by examining the basic functions of protocols and reviewing the protocol characterization criteria identified in

¹ This guide is under the jurisdiction of ASTM Committee F25 on Ships and Marine Technology and is the direct responsibility of Subcommittee F25.05 on Computer Applications.

Current edition approved Feb. 1, 2022. Published April 2022. Originally approved in 1996. Last previous edition approved in 2015 as F1757 – 96 (2015). DOI: 10.1520/F1757-96R22.

this guide, the user will be more apt to understanding other protocols not mentioned or addressed herein.

1.5 *This international standard was developed in accordance with internationally recognized principles on standardization established in the Decision on Principles for the Development of International Standards, Guides and Recommendations issued by the World Trade Organization Technical Barriers to Trade (TBT) Committee.*

2. Referenced Documents

2.1 *ASTM Standards:*²

E1013 Terminology Relating to Computerized Systems (Withdrawn 2000)³

2.2 *ANSI Standards:*⁴

X3T9.5 High Speed Local Network

X3.139 Fiber Distributed Data Interface (FDDI) – Token Ring Media Access Control (MAC)

X3.148 Fiber Distributed Data Interface (FDDI) – Token Ring Physical Layer Protocol (PHY)

X3.166 Fiber Distributed Data Interface (FDDI) – Token Ring Physical Layer Medium Dependent (PMD)

X3.172 American National Standard Dictionary for Information Systems

2.3 *IEEE Standards:*⁵

100 Standard Dictionary for Electrical and Electronic Terms

610 Standard Glossary for Software Engineering Terminology

610.7 Standard Glossary of Computer Networking Terminology

802.1 High Level Interface (Internetworking)

802.2 Logical Link Control

802.3 CSMA/CD Medium Access Control

802.4 Token Bus Medium Access Control

² For referenced ASTM standards, visit the ASTM website, www.astm.org, or contact ASTM Customer Service at service@astm.org. For *Annual Book of ASTM Standards* volume information, refer to the standard's Document Summary page on the ASTM website.

³ The last approved version of this historical standard is referenced on www.astm.org.

⁴ Available from American National Standards Institute (ANSI), 25 W. 43rd St., 4th Floor, New York, NY 10036, <http://www.ansi.org>.

⁵ Available from Institute of Electrical and Electronics Engineers, Inc. (IEEE), 445 Hoes Ln., P.O. Box 1331, Piscataway, NJ 08854-1331, <http://www.ieee.org>.

[802.5 Token Ring Medium Access Control](#)
[802.6 Metropolitan Area Networking](#)
[802.8 Fiber Optic Technical Advisory Group](#)
[802.9 Local and Metropolitan Area Networks: Integrated Services \(IS\) LAN Interface at the Medium Access Control \(MAC\) and Physical \(PHY\) Layers](#)
[803.5](#)
[2.4 ISO Standards:⁴](#)
[7498 Information Processing Systems—Open Systems Interconnection—Basic Reference Model](#)
[9040/9041 Virtual Terminal \(VT\)](#)
[8831/8832 Job Transfer and Manipulation \(JTM\)](#)
[8571/8572 File Transfer Access Management \(FTAM\)](#)
[9595/9596 Common Management Information Service/Protocol \(CMIP\)](#)
[8823 Connection Oriented Presentation Protocol](#)
[8327 Connection Oriented Session Protocol](#)
[8073 Connection Oriented Transport Protocol](#)
[8473 Connectionless Network Service](#)
[8208 Packet Level Protocol](#)
[8802-2 Logical Link Control](#)
[9314-2 FDDI](#)
[8802-3 CSMA/CD \(Bus\)](#)
[8802-4 Token Bus](#)
[8802-5 Token Ring](#)
[7776 Link Access Protocol/Link Access Protocol-Balanced \(LAP/LAPB\)](#)
[7809 High-Level Data Link Control \(HDLC\)](#)
[2.5 ITU Standards:⁶](#)
[X.25 Packet Level Protocol](#)
[X.226 Connection Oriented Presentation Protocol](#)
[X.225 Connection Oriented Session Protocol](#)
[X.224 Connection Oriented Transport Protocol](#)
[2.6 CCITT Standards:⁷](#)
[V.35](#)
[X.21 \(BIS\) Interface Between Data Terminal Equipment \(DTE\) and Data Circuit-Terminating Equipment \(DCE\) for Synchronous Operation on Public Data Networks](#)
[X.25 Interface Between Data Terminal Equipment \(DTE\) and Data Circuit Terminating Equipment \(DCE\) for Terminals Operating in the Packet Mode and Connected Public Data Networks by Dedicated Circuit](#)
[2.7 EIA/TIA Standard:⁷](#)
[232C](#)
[568 Commercial Building Telecommunications Wiring Standard \(ANSI/EIA/TIA-568-91\)](#)
[2.8 Internet Request for Comments \(RFCs\) Standards:⁸](#)
[RFC 768 User Datagram Protocol \(UDP\)](#)
[RFC 791 Internet Protocol \(IP\)](#)
[RFC 792 Internet Control Message Protocol \(CMP\)](#)
[RFC 793 Transmission Control Protocol \(TCP\)](#)

[RFC 821 Simple Mail Transfer Protocol \(SMTP\)](#)
[RFC 826](#)
[RFC 854 TELNET Protocol](#)
[RFC 894](#)
[RFC 903](#)
[RFC 959 File Transfer Protocol \(FTP\)](#)
[RFC 1042](#)
[RFC 1157 Simple Network Management Protocol](#)
[RFC 1201](#)

3. Terminology

3.1 Definitions:

3.1.1 The terminology used in this guide is defined in Terminology [E1013](#), IEEE 610, and ANSI X3.172, with the following additions defined in [3.2](#).

3.2 Definitions of Terms Specific to This Standard:

3.2.1 *bridge, n*—a device that interconnects local or remote networks no matter what network protocol that is, TCP/IP or IPX, are involved. Bridges form a single logical network.

3.2.2 *hub, n*—a central location for the attachment of cables from nodes and other network components.

3.2.3 *internetwork, n*—a collection of LANs using different network operating systems that are connected to form a larger network.

3.2.4 *LAN (local area network), n*—a data communication system consisting of a collection of interconnected computers, sharing applications, data and peripherals.

3.2.5 *network operating system (NOS), n*—the software for a network that runs in a file server and control access to files and other resources from multiple users.

3.2.6 *node(s), n*—any intelligent device connected to the network. This includes terminal servers, host computers, and any other devices, such as printers and terminals, that are directly connected to the network.

3.2.7 *protocol, n*—a standard method of communicating over a network.

3.2.8 *repeater, n*—a network device that repeats signals from one cable onto one or more other cables, while restoring signal timing and waveforms.

3.2.9 *router, n*—a device capable of filtering/forwarding packets based upon data link layer information.

3.2.10 *server, n*—a device that stores data for network users and provides network access to that data.

3.2.11 *topology, n*—the arrangement of the nodes and connecting hardware that comprises the network.

3.2.12 *WAN (wide area network), n*—a network using common carrier transmission services for transmission of data over a large geographical area.

4. Significance and Use

4.1 This guide is intended to provide an understanding of the wide range of communication protocols standards, allowing the user to understand better their applicability to shipboard networks and marine platform computerized systems. For computerized networks and systems, communication protocols are necessary for integrating various system devices, providing

⁶ Available from Electronic Industries Alliance (EIA), 2500 Wilson Blvd., Arlington, VA 22201, <http://www.eia.org>.

⁷ Available from the U.S. Department of Commerce, National Technical Information Service (NTIS), 5285 Port Royal Rd., Springfield, VA 22161, <http://www.ntis.gov>.

⁸ Documents may be obtained by means of anonymous ftp from the hosts:ds.internic.net, directory rfc.

functionality between dissimilar subnetworks, or for enabling remote connections, either pier side or through geophysical communication technologies.

4.2 The wide variety and scope of digital communication protocol standards adds greatly to the complex decision process for specifying compatible protocols for system applications and related devices for the myriad of potential shipboard systems. However, the user must identify the initial networking requirements, so once the network protocols under evaluation are well understood, the decision process should determine the appropriate network protocols. Therefore, this guide is intended to reduce the complexity involved with protocol selection and implementation.

4.3 Network protocols define an agreed, quantifiable entity, or set of rules, by which user computers, system networks, and internetworking devices communicate and exchange information. Communication protocols specify essential networking guidelines, such as physical interface connections, or data format and control operations between two communicating computers. Ship and marine digital communication protocol requirements are no different than their land-based networked counterparts. Both require standardized protocol selection, in various protocol categories, including LAN standards, WAN protocols, LAN/WAN protocols, network management, wiring hub configurations/operations, hardware platforms, operating systems, and network applications.

5. Origin of Protocol Development

5.1 Communication protocol standards have been developed or refined through three separate processes, identified as follows:

5.1.1 *Defacto Protocol Standards*—Acquired widespread use of a popular technique adopted by vendors and developers;

5.1.2 *Dejur Protocol Standards*—Standards making bodies; and,

5.1.3 *Proprietary Protocol Standard*—Private corporation-based protocols with limited interoperability.

5.2 The open standards approach is now the norm, which allows multiple protocol networking solutions to be available, and as a result, proprietary protocols are now becoming obsolete.

6. Local Network Interconnection

6.1 The characteristic of a local network is determined primarily by three factors: transmission medium, topology, and medium access control protocol.

6.1.1 The principal technological elements that determine the nature of a local network are the topology and transmission medium of the network. Together, it determines the type of data that may be transmitted, the speed and efficiency of communications, and the type of applications that a network may support.

6.1.2 Interconnecting a set of local networks is referred to as an internetworking. The local networks are interconnected by devices generically called gateways. Gateways provide a communication path so that data can be exchanged between networks.

6.2 *Topology*—The common topologies used for local networks are star, ring, and bus/tree (see Fig. 1).

6.2.1 *Star Topology*—In a star topology, a central switching element is used to connect all the nodes in the network. The central element uses circuit switching to establish a dedicated path between two stations wishing to communicate (see Fig. 1).

6.2.2 *Ring Topology*—The ring topology consists of a closed loop, with each node attached to a repeating element. Data circulate around the ring on a series of point-to-point data links between repeaters. A station wishing to transmit waits for its next turn and then sends data out onto the ring in the form of a packet (see Fig. 1).

6.2.3 *Bus/Tree Topology*—The bus or tree topology is characterized by the use of a multipoint medium. The bus is simply a special case of the tree, in which there is only one trunk, with no branches. Because all devices share a common communications medium, only one pair of devices on a bus or tree can communicate at a time. A distributed medium access protocol is used to determine which station may transmit (see Fig. 1).

6.3 *Internetwork Topology*—The common topologies used to support emerging networking topologies requiring the integration of data, video and voice, as well as higher transport bandwidth are backbone, hierarchical, and mesh (see Fig. 2).

6.3.1 *Backbone*—Backbone configurations are used in networking environments in which local networks are connected over high-speed backbone cables. Bridges and routers are used to manage the data passing between interconnected networks and the backbone (see Fig. 2).

6.3.2 *Hierarchical*—In the hierarchial configuration, star-configured hubs are wired to a central hub that handles interhub traffic. Routers and Asynchronous Transfer Mode (ATM) technology provide support to traffic intensive network applications requiring the integration of voice, video, and data (see Fig. 2).

6.3.3 *Mesh*—In mesh configurations, there are at least two pathways to each node. This is a common configuration in emerging high-speed enterprise networks requiring the integration of voice, video, and data. It is composed of internetworking devices, such as bridges, routers, and ATM technology. The

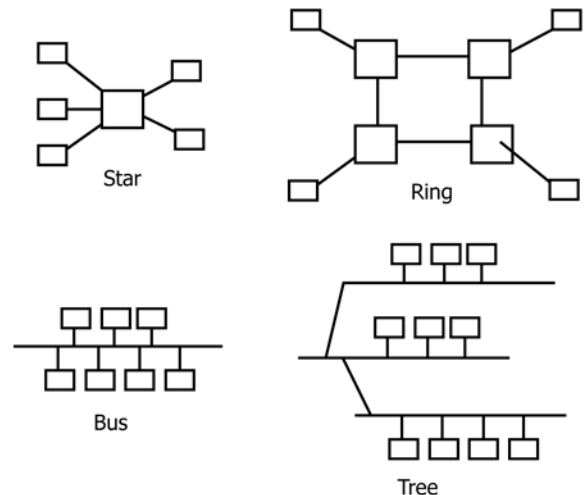

FIG. 1 Local Network Topologies